

PERKEMBANGAN SMART DISTRIBUTION SEASONING SYSTEM

MENGGUNAKAN DELPHI 7 BERBASIS ORANGE PI

Ratna Gusrianti¹⁾, Retno Devita²⁾, Yogi Wiyandra³⁾

¹⁾Sistem Komputer, Fakultas Ilmu Komputer, Universitas Putra Indonesia “YPTK” Padang, Indonesia.

²⁾Sistem Komputer, Fakultas Ilmu Komputer, Universitas Putra Indonesia “YPTK” Padang, Indonesia.

³⁾Sistem Komputer, Fakultas Ilmu Komputer, Universitas Putra Indonesia “YPTK” Padang, Indonesia.

ratnagusrianti1408@gmail.com

Abstract

Kitchen seasonings are substances that generally come from aromatic plants which are added to dishes with the aim of flavoring food. Seasoning serves to make food taste better. Delicious or not a food depends on the spices added. Seasoning is made from a mixture of spices through various processing processes. Generally, cooking spices are classified into three groups, namely red, white and yellow main spices. Many types of spices can be made into seasonings, for example coriander, pepper, black pepper. There are various types of spices, so storage in the warehouse requires a place that is suitable for the types of spices. So that suppliers are not confused about storing kitchen spices and if needed they are not confused anymore. The supplier will send the spices according to consumer demand, samples in kilo sizes according to the space provided and there will be no more mistakes. This research was carried out by designing, manufacturing and implementing the process, LCD as an information display, Load Cell as a detector for spices, and speakers providing information in the form of sound covering the microcontroller controlling the process, namely the Orange Pi.

JCSITech is licensed under a Creative Commons 4.0 International License.



1. Introduction

Due to the variety of kitchen spices, warehouse storage requires compartments suitable for each type of seasoning. This prevents suppliers from being confused about storing the seasonings and makes retrieval easier when they are needed. Suppliers will send seasonings according to consumer demand, such as by kilograms, using the space already provided, thus avoiding errors. When a seasoning supply runs out, Delphi will automatically instruct the system to monitor and request replenishment. Consumer demand determines the required seasoning amount, and a database collects all data. RFID is used to obtain customer data via ID cards for access to the seasoning storage warehouse.

2. Research Method

To get optimal results, a research framework is needed. In this research framework, the stages of a research conducted will be described to simplify the steps of the creation, so that it can be used as a guideline in solving existing problems. The research framework

that will be reference in the text.

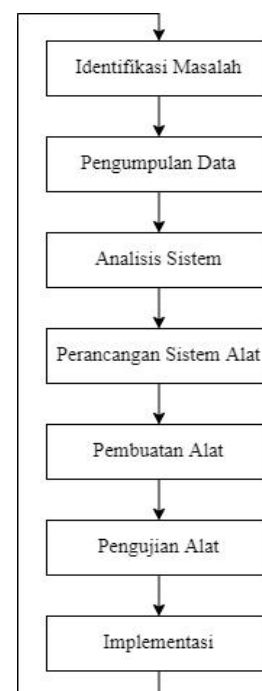

Figure 1. Research Framework

2.1 System Design

In designing this system, several tools are needed, namely:

1. Context Diagram. A context diagram illustrates the overall design. External entities must be depicted in such a way that the data flow from input to process to output is visible.

2. Data Flow Diagram (DFD). A Data Flow Diagram (DFD) is a diagram that depicts the flow of data within an entity or system to an entity. DFD can also be defined as a graphical technique that depicts the data flow and transformations used as data travels from input to output.

3. Block Diagram.

Block diagrams are created to map the work process.

In a tool, this aims to make it easier for someone to identify the components.

4. Flowchart: A flowchart is a graphical representation of the steps and sequence of procedures in a program. Flowcharts help analysts and programmers solve problems in smaller segments and assist in analyzing alternative operations, especially those requiring further study and evaluation.

5. Software Design

The software design of the tool created consists of a preliminary outline and form of the overall tool. This design allows for a clearer understanding of the tool's operating principles and the system components used. The software used to design the tool is Google SketchUp.

The electronic components of the device and understanding its workflow.

1. Flowchart: A flowchart is a graphical representation of the steps and sequence of procedures in a program. Flowcharts help analysts and programmers solve problems in smaller segments and assist in analyzing alternative operations, especially those requiring further study and evaluation.

2. Software Design

The software design of the device being created consists of a preliminary image and form of the device as a whole. This design allows the device's operating principles and system components to be clearly visible. The software used for device design is Google SketchUp.

2.2 System Analysis

The analysis phase is the most crucial stage in system development. In this analysis, researchers aim to explain the input, output, and process of the system to be created. This aims to ensure problem-solving can produce a new solution. Based on problem identification, researchers conduct data analysis. This aims to ensure problem-solving can produce a new

solution before designing a tool.

In this analysis, researchers aim to explain the input, output, and process of the system to be created. Input is input that will be processed and produce an output. The input components used are RFID, which functions to read incoming data from RFID tags and then send it to the Raspberry Pi; a monitor, which functions to display customer data on kitchen spice purchases; a servo motor, which functions to open and close the valve in the kitchen spice storage; a speaker, which functions to emit sound in the kitchen spice supply system; a webcam, which functions to monitor and monitor the operation of the kitchen spice supply system; and Delphi 7, which functions to display data on the kitchen spice supply and act as an instruction provider.

2.3 System Testing

The smart distribution seasoning prototype design using Delphi 7 and a Raspberry Pi for testing is as follows:

Connect a monitor to the device, then turn on the system. The monitor will display the display. Open the application created in Delphi 7. Once opened, the application page will appear. The application will display spice supplier data and provide instructions for running the system. The RFID module will read the data and send it to the Raspberry Pi.

3. Result and Discussion

3.1 Context Diagram

A context diagram is a comprehensive definition of the system to be designed. This context diagram is used to facilitate the design process. Analyzing the designed system as a whole. Context diagrams function as a medium, which consists of a process and several external entities. The context diagram should be referenced in the text.

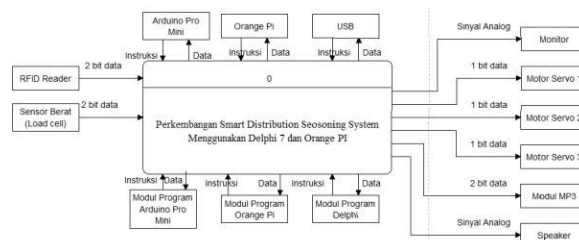

Figure 2 Context Diagram

3.2 Data Flow Diagram

A data flow diagram is a more detailed depiction of the designed tool. It's described based on the context diagram described previously. A data flow diagram figure should be reference in the text.

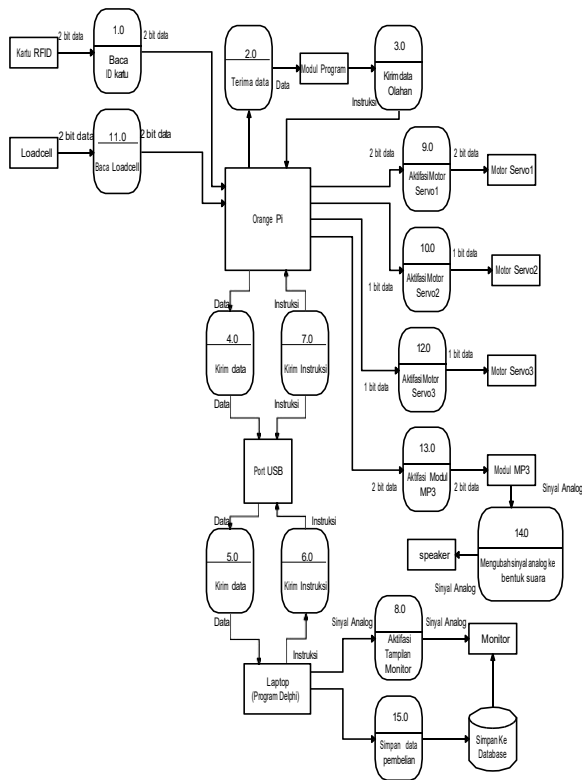

Figure 3 Data Flow Diagram

3.3 System Working Principle

In general, this tool consists of electronic circuits, and the system will operate in a structured manner depending on the design. Here's how the system works in a structured manner.

1. This GUI-based kitchen spice supply system prototype uses an RFID reader to read RFID tags as customer identifiers for purchasing kitchen spices. This information is then sent to Delphi 7 to verify the data in the database.
2. After the data is confirmed, Delphi 7 will send instructions to Orange Pi to open the spice storage valve as requested.
3. After the valve is opened in the spice storage area, the load cell will read the weight of the distributed spices.
4. The servo motor will open the valve according to Orange PI's instructions.
5. The monitor will display the spice supply system data.
6. The database will store purchase and sales data for customers.

3.4 Physical Design of the Tool

The design of this tool is the initial stage of installation and analysis of the problems encountered based on supporting literature. The physical design of the tool figure should be reference in the text.

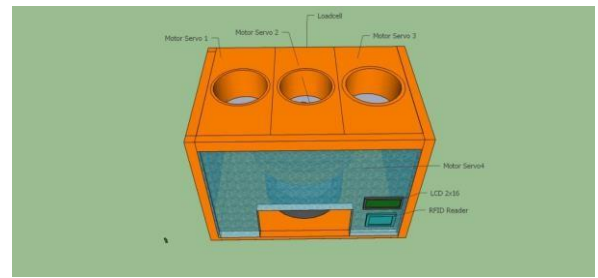

Figure 5. Physical Design of the Tool

4. Conclusion

Orange Pi and Delphi can be used as instruction and data processing centers for designing a prototype smart distribution seasoning system. RFID is used as access for consumers to purchase spices. Delphi 7 can be used as a processing and storage facility for spice sales, creating a system that can assist warehouse owners in distributing spices. This system can monitor and execute the spice distribution process without human labor. Load cell sensors are used to determine the weight of spices purchased by consumers.

References

- Alam, Hermansyah. 2022. "Penggunaan Sensor Vibration Sebagai Antisipasi Gempa Bumi."
- Hidayat, Fendi. 2019. "Konsep Dasar Sistem Informasi Kesehatan."
- Imam, Fadhlan Fakhrol. 2019. "Purwarupa Smart Door Lock Menggunakan Multi Sensor Berbasis Sistem Arduino."
- Irawan, Indra. 2018. "Pengembangan Sistem Informasi Tagihan (Billing System) Pasien Rawat Inap Pada Rumah Sakit Umum Daerah Bangkinang Kampar."
- Khadir, Abdul. 2019. "Arduino & Johnny Five."
2019. "Konsep Dasar Sistem Informasi Kesehatan." *Fendi Hidayat*.
- Manulang, Andi Boy Panroy. 2021. "Implementasi Nodemcu Esp8266 Dalam Rancang Bangun Sistem Keamanan Sepeda Motor Berbasis Iot."
- Muzhar, Sukardi Ilham. 2021. "Pelontar Bola Tennis Lapangan Otomatis Berbasis Mikrokontroler Arduino Mega2560."
- Novendry, Muhamad Saed. 2019. "Aplikasi Inventaris Barang Pada Mts Nurul Islam Dumai Menggunakan Php Dan Mysql".
- Roni, Kiagus Ahmad. 2020. "Sistem Kendali Proses Industri."
- Samuel Beta, Sri Astuti. 2019. "Modul Timbangan Benda Digital Dilengkapi Led RGB dan DFPlayer Mini."
- Santoso, Hari. 2017. "Arduino Untuk Pemula."
- Setiawardhana, Sigit Wasista. 2019. "19 Jam Belajar Cepat Arduino."
- Syaiful Indra, Hajra Rasmitha. 2017. "Perancangan Prototype Teknologi RFID dan Keypad 4x4 Untuk Keamanan Ganda Pada Pintu Rumah."
- Wahyudi, Rahman Rahman. 2017. "Jurnal ELKOMIKA Vol.5 No.2 Desember."